



RV Products Division

**Airxcel, Inc.
RV Products Division
P.O. Box 4020
Wichita, KS 67204**

TABLE OF CONTENTS

I.	General Information	2
II.	Air Conditioning Sizing	3
III.	Selecting An Installation Location	3
IV.	Installing The Roof Top Unit	3
V.	Securing The Air Conditioner To The Roof	6
VI.	Electrical Wiring	7
VII.	Installing The Ceiling Assembly (9000 Series)	8
VIII.	Completing The Installation (9000 Series)	10

These instructions are a general guide for installing the International Series Coleman - Mach roof top air conditioners. For specific air conditioner details, it will be necessary to refer to the printed Customer Envelope Package supplied with each air conditioner.

IMPORTANT NOTICE

These instructions are for the use of qualified individuals specially trained and experienced in installation of this type equipment and related system components.

Installation and service personnel are required by some states to be licensed. **PERSONS NOT QUALIFIED SHALL NOT INSTALL NOR SERVICE THIS EQUIPMENT.**

NOTE

The words "Shall" or "Must" indicate a requirement which is essential to satisfactory and safe product performance.

The words "Should" or "May" indicate a recommendation or advice which is not essential and not required but which may be useful or helpful.

WARNING - SHOCK HAZARD

To prevent the possibility of severe personal injury or equipment damage due to electrical shock, always be sure the electrical power source to the appliance is disconnected.

CAREFULLY FOLLOW ALL INSTRUCTIONS AND WARNINGS IN THIS BOOKLET TO AVOID DAMAGE TO THE EQUIPMENT, PERSONAL INJURY OR FIRE.

WARNING

Improper installation may damage equipment, can create a hazard and will void the warranty.

The use of components not tested in accordance with these units will void the warranty, may make the equipment in violation of state codes, may create a hazard and may ruin the equipment.

I. GENERAL INFORMATION

OEM - Please make sure the Customer Envelope Package accompanies the air conditioner.

INSTALLER AND/OR DEALER - Please make sure the Customer Envelope Package is presented to the product consumer.

INQUIRIES ABOUT THE A/C UNIT - Inquiries to your Airxcel, Inc. representative or to Airxcel, Inc. pertaining to product installation should contain both the model and serial numbers of the roof top air conditioner. All roof top air conditioning units have model and serial number identification in two locations; 1) rating plate sticker may be viewed by looking through the shroud louvers on the compressor side of the roof top air conditioning unit. The rating plate sticker can be seen without removing the outer plastic shroud,

2) model/serial number sticker (silver color) is located on the bottom or inside the return air opening of the basepan of the roof top air conditioner. If the air conditioner is installed, the sticker may be viewed by lowering the ceiling assembly shroud.

NOTE

All 8000 series roof top air conditioners should be installed with a 9000 series ceiling assembly.

All 6700 series roof top air conditioners should be installed with a 6700 series ceiling assembly.

II. AIR CONDITIONING SIZING

The ability of an air conditioner to cool a vehicle or maintain a consumer desired temperature is dependent on the heat gain of the vehicle. The physical size, the window area, the quality and amount of insulation, the exposure to sunlight, the number of people using the vehicle and the outside temperature, may increase the heat gain such that the capacity of the air conditioner is exceeded.

As a general rule, air supplied (discharge air) from the air conditioner will be 15 to 20 degrees cooler than the air entering (return air) the ceiling assembly bottom air grilles.

For example, if the air entering the air conditioner is 80 degrees F (return air), the supply air (discharge air) into the vehicle will be 60 to 65 degrees F. As long as this temperature difference

(15 to 20 degrees) is being maintained, the air conditioner is operating properly.

Again, give careful consideration to the vehicle heat gain variables. During extreme outdoor temperatures, the heat gain of the vehicle may be reduced by:

- ◆ parking the vehicle in a shaded area
- ◆ keeping windows and doors closed
- ◆ avoiding the use of heat producing appliances
- ◆ using window shades (blinds and/or curtains)

For a more permanent solution to high heat gain situations, additional vehicle insulation, window awnings and/or window glass tinting should be considered.

III. SELECTING AN INSTALLATION LOCATION

Your Coleman - Mach air conditioner has been designed for use primarily in recreational vehicles.

Is the roof of the vehicle capable of supporting both the roof unit and ceiling assembly without additional support structures? Inspect the interior ceiling mounting area to avoid interference with existing structural members such as: bunks, curtains, tracks or room dividers. The depth of the ceiling assembly shroud is 3". Be sure to check clearance to doors which must be swung open (refrigerator - closets - cabinets).

Most of the time, roof mount air conditioners are installed at existing roof vent locations. If there are no roof vents (existing mounting hole), the following placement locations are recommended.

Motorhomes - a single unit or the forward of two units should be mounted within 9 feet of the drivers compartment.

Travel Trailers or Mini-Homes - a location should be selected that is near the door slightly forward of the vehicle center length.

Vans - location should be in the center of the roof (side to side - front to back).

Truck with Camper - location should be between 4 and 5 feet from the rear of the camper to achieve maximum cooling effect.

IV. INSTALLING THE ROOF TOP UNIT

⚠ DANGER SHOCK HAZARD

DISCONNECT ALL POWER TO THE VEHICLE BEFORE PERFORMING ANY CUTTING TO THE VEHICLE. CONTACT WITH HIGH VOLTAGE CAN RESULT IN EQUIPMENT DAMAGE, PERSONAL INJURY OR DEATH.

IMPORTANT

TO PREVENT DAMAGE TO THE WIRING AND BATTERY, DISCONNECT THE BATTERY CABLE FROM THE POSITIVE BATTERY TERMINAL BEFORE PERFORMING ANY CUTTING TO THE VEHICLE.

Once the location for your air conditioner has been determined (See Section III), a reinforced and framed roof hole opening must be provided (may use existing vent hole). Before cutting into the vehicle roof, verify that the cutting action will clear all structural members and crossbeams. Additionally, the location of any inner roof plumbing and electrical supplies must be considered.

A. If a roof vent is already present in the desired mounting location for the air conditioner, the following steps must be taken.

1. Remove all screws which secure the roof vent to the vehicle. Remove the vent and any additional trim materials. Carefully

remove all caulking from around the roof opening to obtain clean exterior roof surface.

2. It may be necessary to seal some of the old roof vent mounting screw holes which may fall outside of the air conditioner basepan gasket.
3. Examine the roof opening. If the opening is smaller than 14" x 14", the opening must be enlarged.

B. If a roof vent opening is not used, a new opening (See Figure 1) will have to be cut into the vehicle roof. A matching opening will also have to be cut into the interior vehicle ceiling. If the ceiling opening is carpeted, snagging could occur. After the opening in the roof and interior ceiling are the correct size, a framed support structure must be provided between the exterior roof top and interior ceiling. The reinforced framed structure must provide the following guidelines:

1. Capable of supporting both the weight of the roof top air conditioner and the interior ceiling assembly.
2. Capable of holding or supporting the roof outer surface and interior ceiling apart, so that when the roof top air conditioner and ceiling assembly are bolted together, no collapsing occurs.

Airxcel, Inc. recommends that the spacing from the vehicle roof top to the interior ceiling top be no less than 1". A typical support frame is shown in Figure 1.

The frame must provide an opening through the frame to allow passage for the power supply wiring. Route the supply wiring through the frame at the same time the support frame is being installed.

IMPORTANT – Allow 24" of supply wiring through the support frame (working length).

After the support frame is installed, seal all gaps between the frame and both the roof exterior and the interior ceiling of the vehicle (cavity walls). Additionally, seal the gap around the electrical supply wiring.

- C. The air conditioner must be mounted as near level from front to rear and side to side as is possible when the vehicle is parked on a level plane. Figures 2 and 3 show maximum allowable degree deviations (mounting degrees from total surface flat plane).

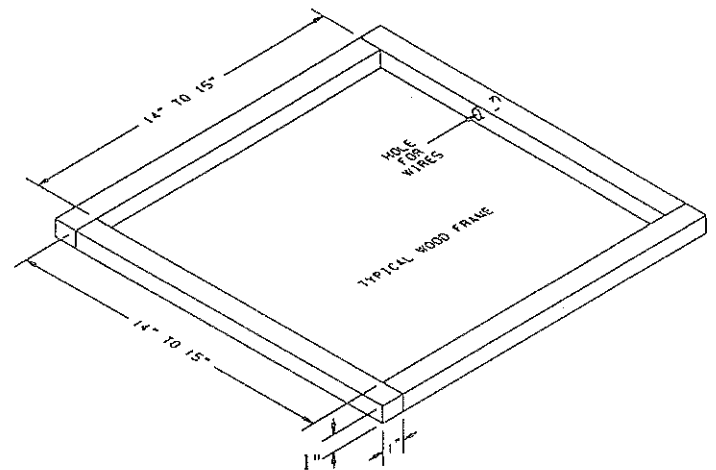

FIGURE 1

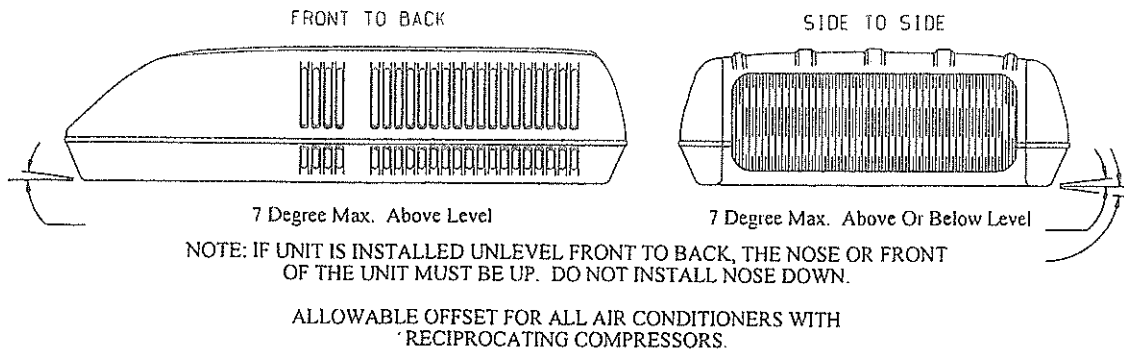

FIGURE 2

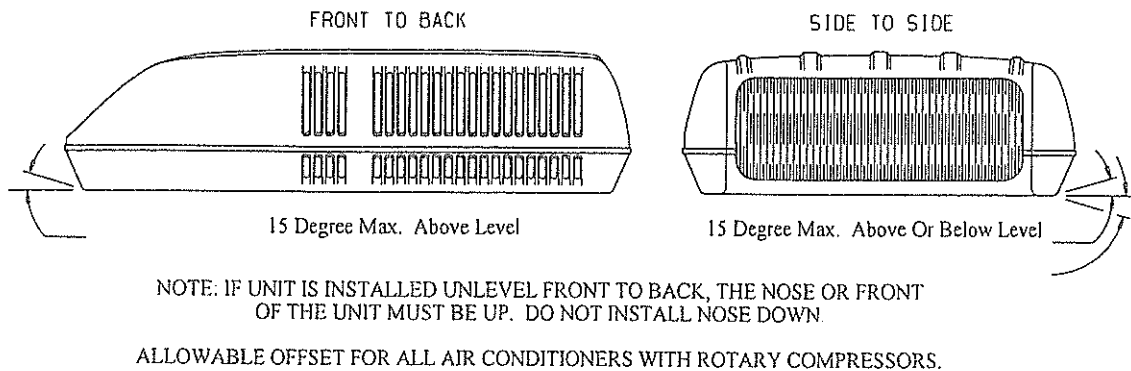

FIGURE 3

If the roof of the vehicle is sloped (not level) such that the air conditioner cannot be mounted within the maximum allowable degree deviations, an exterior leveling shim will need to be added to make the air conditioner level. A typical front to back leveling shim is shown in Figure 4.

Once the air conditioner has been leveled, some additional shimming may be required above the interior ceiling assembly. The air conditioner and the interior ceiling assembly must have a squared installation relationship before they are secured together.

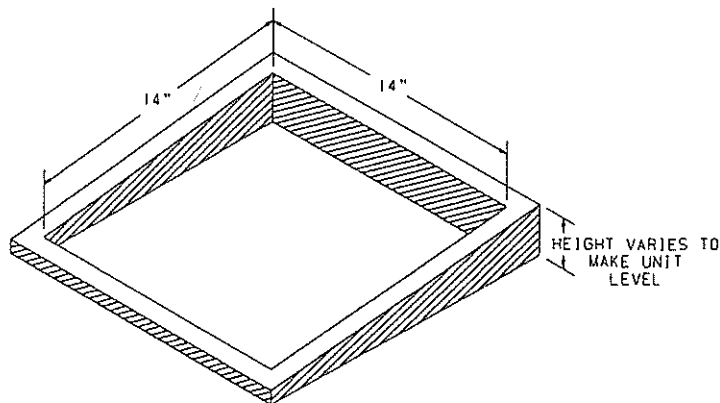

FIGURE 4

- D. After the mounting hole is properly prepared, remove the carton and shipping pads from around the air conditioner. **Carefully** lift the unit to the top of the vehicle. Do not use the outer plastic shroud for lifting. Place the air conditioner over the prepared mounting hole. The pointed end (nose) of the shroud must face towards the front of the vehicle. Pull the electrical conduit down from the air conditioner through the mounting opening and let hang.

V. SECURING THE AIR CONDITIONER TO THE ROOF

A mounting frame is supplied with the ceiling assembly. Follow the steps below to secure the air conditioner to the roof. Refer to Figure 5.

- A. Locate the air conditioner mount gasket over the 14" to 15" square opening in the roof.
- B. Install the ceiling assembly mount frame using the four bolts found with the ceiling assembly.

- C. Proper tension has been achieved for each bolt when any portion of each gasket indicating tab has been pulled down even with the roof. See Figure 5. The upper unit has now been properly installed with optimum gasket compression.

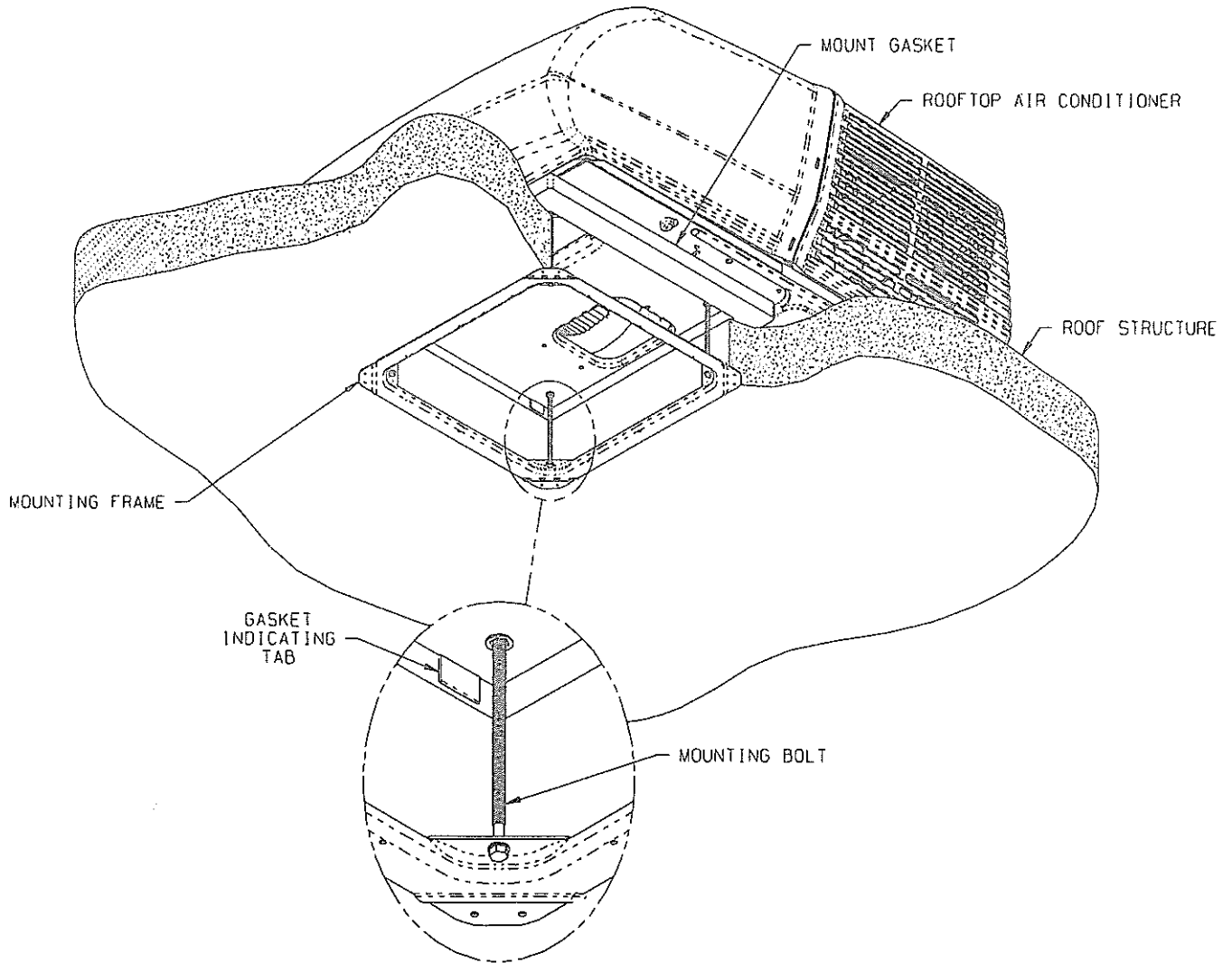

FIGURE 5

VI. ELECTRICAL WIRING

ROUTING 115 VAC WIRING

Following Airxcel, Inc. high voltage wiring specifications and all local and national electrical codes, route the roof top unit 115 VAC supply wiring from its power source to the wirebox.

High Voltage Wiring Specifications

1. U.L. requires copper conductors only with minimum #12 AWG.
2. To prevent voltage drops greater than 10% during starting loads, adhere to the following guideline:

For lengths greater than 50', use #10 AWG.
Circuit Protection - Refer to upper unit nameplate.

DANGER - SHOCK HAZARD

MAKE SURE THAT ALL POWER SUPPLY TO THE UNIT IS DISCONNECTED BEFORE PERFORMING ANY WORK ON THE UNIT TO AVOID THE POSSIBILITY OF SHOCK INJURY OR DAMAGE TO THE EQUIPMENT.

DANGER

WHEN USING NON-METALLIC SHEATH CABLES (ROMEX, ETC.), STRIP SHEATH BACK TO EXPOSE 4-6 INCHES OF THE SUPPLY LEADS. STRIP THE INDIVIDUAL WIRE LEAD ENDS FOR WIRE CONNECTION (ABOUT 3/4" BARE WIRE). INSERT THE SUPPLY WIRES INTO THE ELECTRICAL CONNECTOR CLAMP. SHEATH MUST PROTRUDE PAST THE CLAMP BUSHING INSIDE THE BOX AS ILLUSTRATED. MAKE SURE SHEATH CABLE IS CENTERED IN CLAMP BEFORE TIGHTENING UP ON IT. DO NOT OVERTIGHTEN!!

THIS COULD RESULT IN PINCHING THROUGH THE PLASTIC WIRE INSULATION AND CAUSE SHORTING OR "HOT" WIRES TO GROUND (SHOCK HAZARD). THE CLAMP IS INTENDED FOR STRAIN RELIEF OF THE WIRES. SLIGHT PRESSURE IS USUALLY SUFFICIENT TO ACCOMPLISH THIS.

IF OTHER THAN NON-METALLIC CABLES ARE USED FOR SUPPLY CONDUCTORS, APPROPRIATE STRAIN RELIEF CONNECTORS OR CLAMPS SHOULD BE USED.

IN NO CASE SHOULD CLAMPING OR PINCHING ACTION BE APPLIED TO THE INDIVIDUAL SUPPLY LEADS (NEUTRAL AND "HOT" WIRES).

DANGER SHOCK HAZARD

TO PREVENT THE POSSIBILITY OF SHOCK INJURY, THE WHITE WIRE MUST BE CONNECTED TO NEUTRAL IN THE SERVICE BOX ENTRANCE AND THE MECHANICAL GROUND MUST BE CONNECTED TO A GROUNDING LUG EITHER IN THE SERVICE BOX OR THE MOTOR GENERATOR COMPARTMENT.

VII. INSTALLING THE CEILING ASSEMBLY (9000 SERIES)

NOTE

The optional Electric Heating Element is intended to take the chill out of the indoor air when the air is a few degrees too cool for comfort. The heating element is an effective "chill chaser". **It is not a substitute for a furnace.**

Make sure that you have properly matched the roof top air conditioner and interior ceiling assembly. The following step by step instructions must be performed in the following sequence to insure proper installation.

- A. Carefully uncarton the ceiling assembly. Controls are factory installed in the ceiling assembly (except ceiling assemblies for applications with remote control box/thermostat).
 - B. Remove the grille and filters from the ceiling assembly.
 - C. If the ceiling assembly is equipped with an Electric Heating Element, remove the heater assembly from the ceiling assembly chute. Position the heater assembly in the air conditioner return air opening as shown in Figure 6. The heater bracket must be installed over the metal basepan extrusion and positioned between the basepan and the plastic drain pan (See Figure 7). Tighten set screw to secure the assembly so as to prevent movement.
- TIE ALL WIRING TO INSURE NO CONTACT WITH THE HEATER OR ANY SHARP EDGES. KEEP IN MIND THAT HIGH VELOCITY AIR WILL BE ENCOUNTERED IN THIS AREA.**
- D. Fasten the duct collar to the basepan of the air conditioner with three (3) screws (See Figure 10).
 - E. Plug the roof top air conditioner electrical conduit into the 9 position receptacle located in the thermostat side of the ceiling assembly. If installing an Electric Heating Element, plug the heater cord into the 2 position receptacle (See Figure 8).
 - F. Insert the supply wiring through the cable clamp and into the field wiring box so that 4 - 6" of supply conductor is inside the box. Secure the cable clamp over the supply wire sheath so that no movement is possible (See Figure 9).
 - G. Connect the supply power conductors to the "A" and "N" lugs on the terminal board. **IMPORTANT -** If power is from one "Hot" and one "Neutral" conductor, connect the neutral to "N". Connect the ground wire to the "E" lug on the terminal board (See Figure 9).

- H. Place the metal control box shield over the thermostat, switch and field wiring boxes. Make certain that all wires are pushed into the control boxes or laying in the wireway between the thermostat and switch boxes and will not be pinched by the control box shield. Control box shield is properly installed when the two holes in the shield are aligned with the two screw holes in the ceiling assembly chute (See Figure 8).

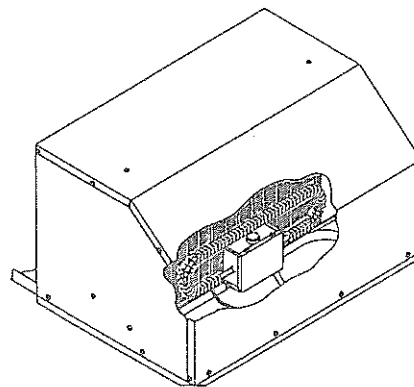

FIGURE 6

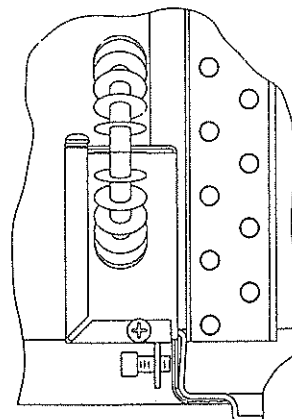

FIGURE 7

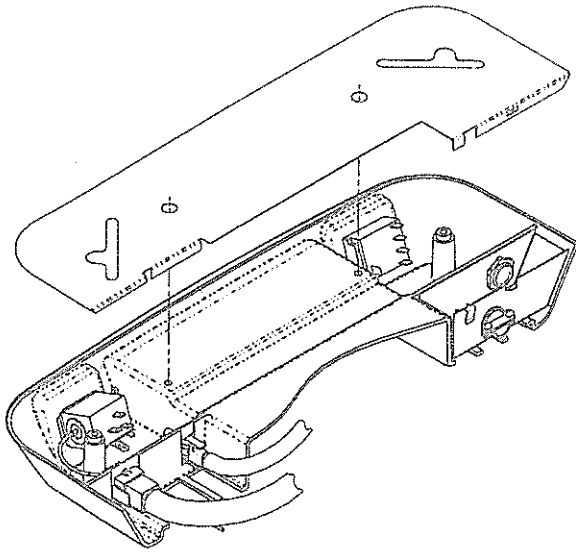

FIGURE 8

- I. Raise the ceiling assembly and secure to the mounting frame with 4 provided shoulder screw/spring assemblies. The front two screws should pass through the clearance holes in the metal control box shield (See Figure 10).
- J. The ceiling assembly shroud is curved to contour to a crowned ceiling. If installation is to a flat ceiling and gaps are present on the sides of the shroud, insert the four optional 3/4 inch screws (provided) through the mounting posts and secure them to the mounting frame above (See Figure 8, 9, & 10 for screw locations).
- K. Pull the fabric duct material through ceiling assembly discharge opening. Peel the release liner from the adhesive strip around the discharge opening. Press the fabric duct material firmly in place around opening. Cut off excess fabric on inside of ceiling assembly chute with a box knife taking care not to tear the fabric beyond the adhesive strip.

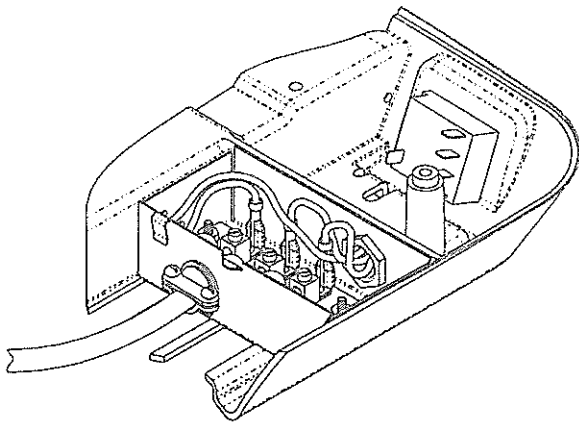

FIGURE 9

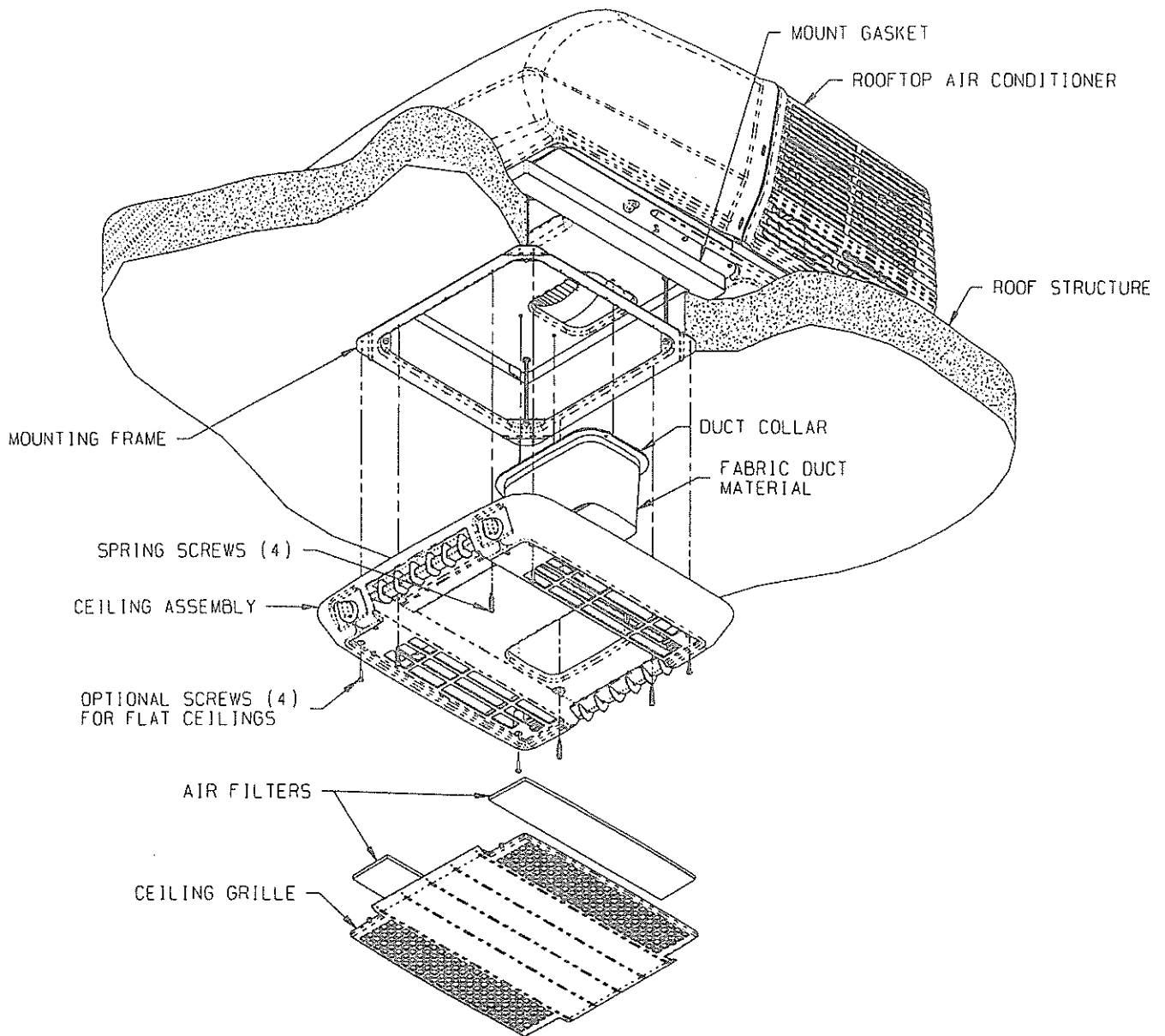

FIGURE 10

VIII. COMPLETING THE INSTALLATION (9000 SERIES)

- A. Make sure the non-allergenic filters are properly positioned in the ceiling grille.
- B. Install the ceiling grille by positioning on the bottom of the shroud and engaging the two 1/4 turn fasteners.
- C. Turn the selector switch to OFF position.
- D. Turn ON the power supply to the roof top air conditioner.
- E. System Checkout - Airxcel, Inc. manufactures a wide range of roof top air conditioners which incorporate different product operation features. To properly evaluate the performance of a newly installed air conditioner, it is necessary to review the specific unit operation characteristics (features) described in product operation and maintenance instructions (Customer Envelope Package).